



CEMCA

Earthing



Learning Objective

By the end this session, you will be able to:

- Explain the process of earthing and testing earth resistance



Open House Discussion

- In case of leakage of current, what happens if you touch a non-current electrical part of an electrical appliance, which is not earthed?
- What is the impact on you if earthing is done?
- Will you receive electric shock in case of leakage of current?
- Why do you not get electric shock when the appliance is earthed?
- What does earthing do to the appliance?
- What is the importance of earthing?



Introduction

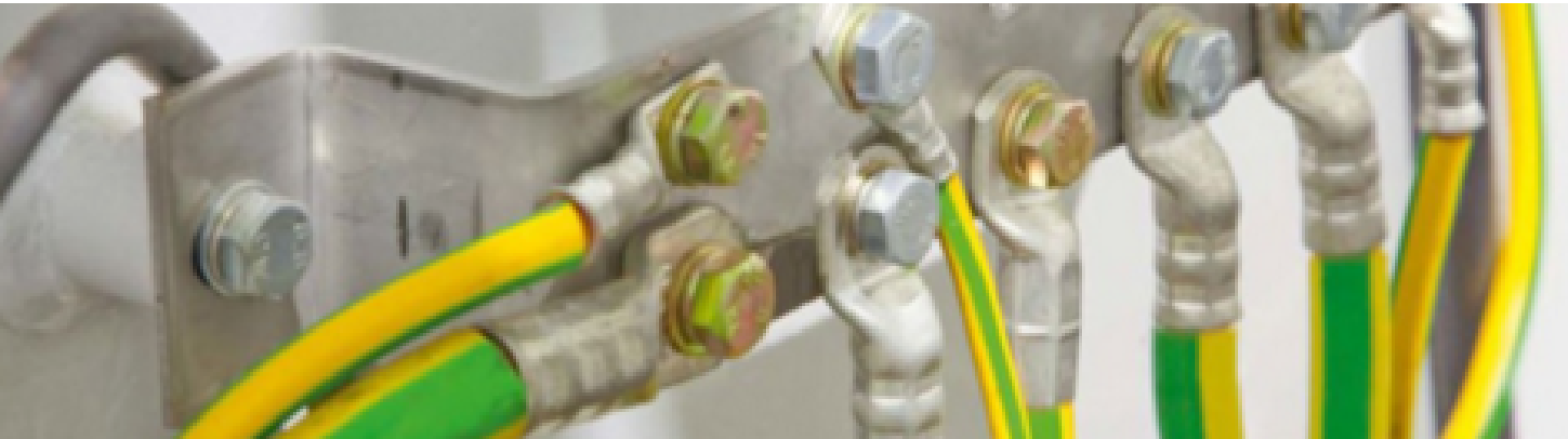
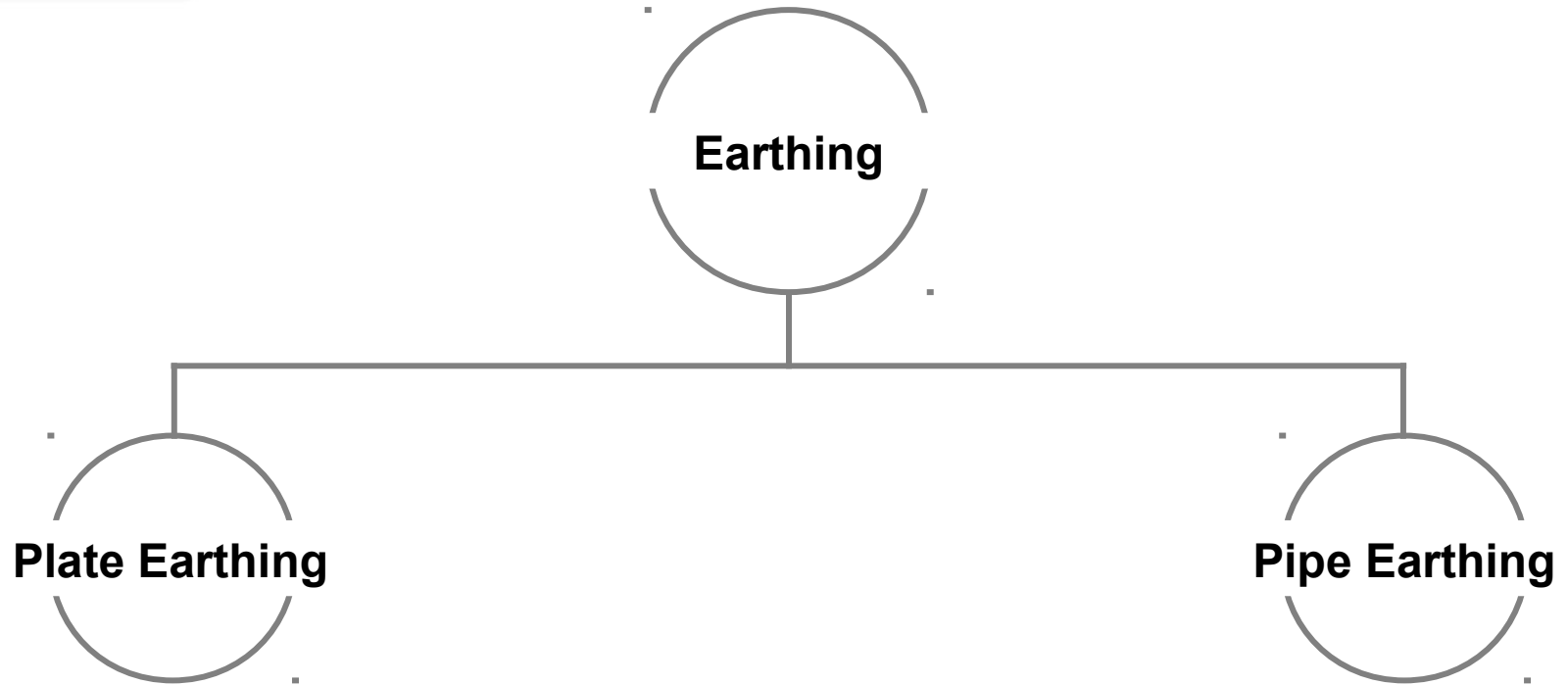

Earthing

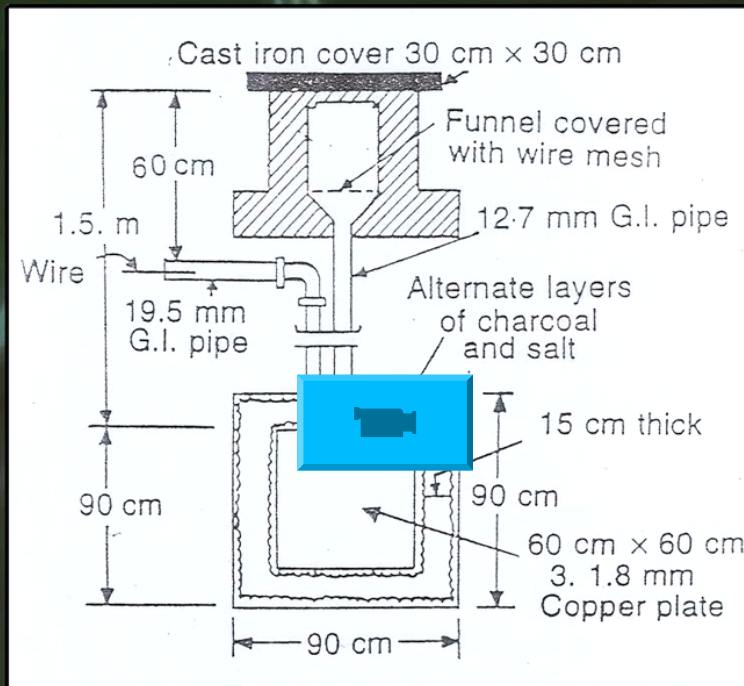

**For the work execution of plate earthing,
make a bore of size 60X60 cm**

Earthing

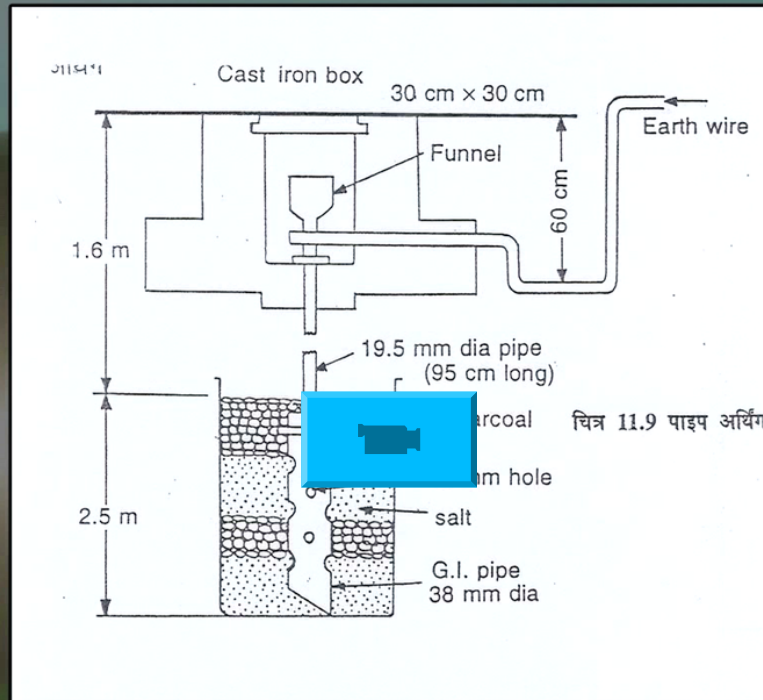

Dig a bore of 4.75 metres depth of size 60X60 cm on the ground.

Earthing the Equipment

Structure of the Distribution Substation of 11 KV/433-250 Volts

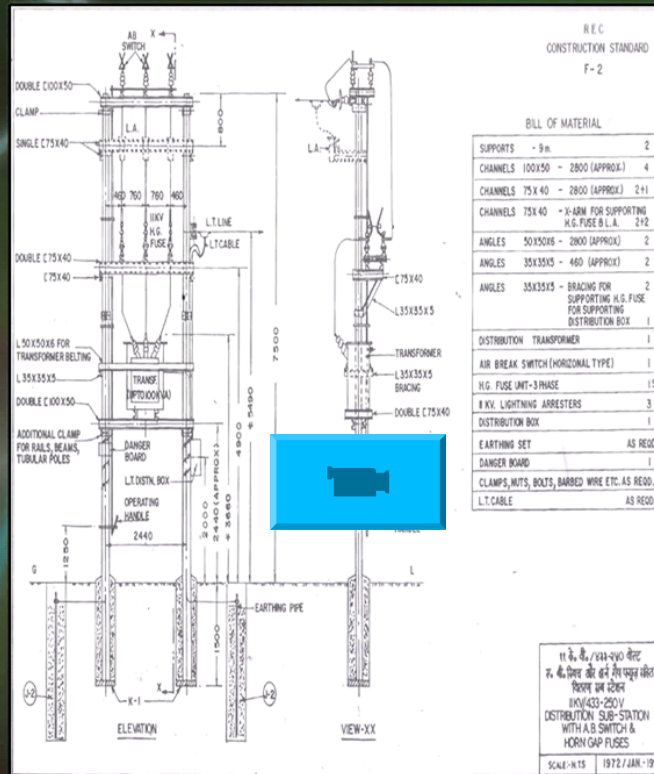

Earthing

A typical arrangement of earthing the equipment

Earthing

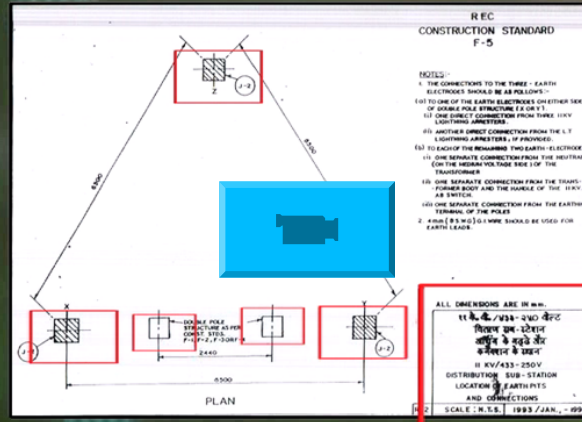

As shown in the figure, the earth pits

Structure of the Distribution Substation as per REC Construction Standard F-10

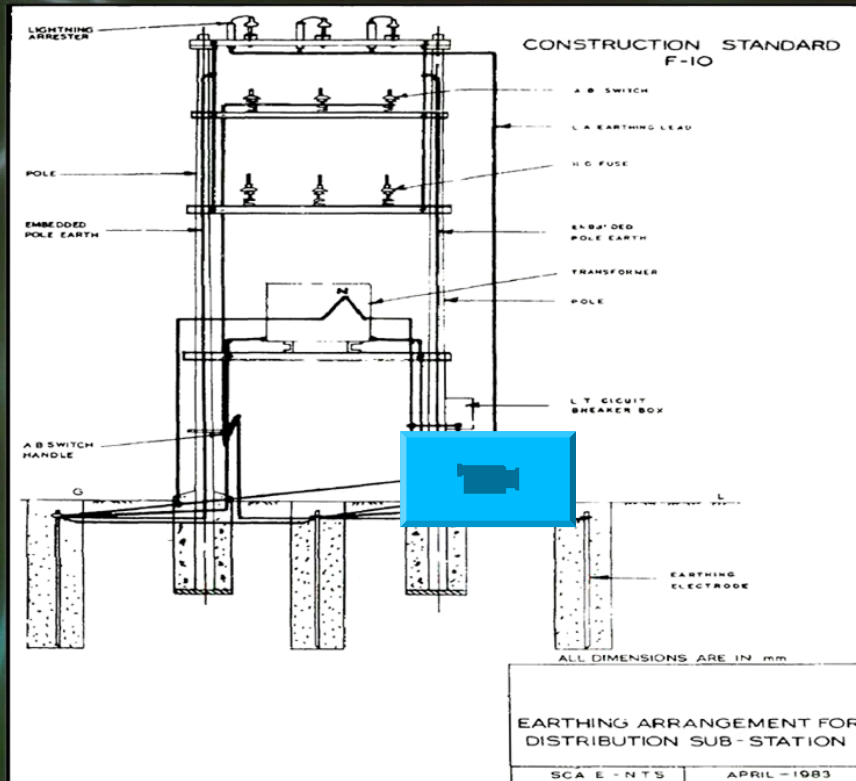

Earthing

A typical arrangement of earthing the equipment and structure

Earthing Pit



Connection from the transformer body

Connection from the transformer body

The transformer is connected to three such earthing pits.

Inside the Earthing Pit



Measurement of Electrode:

- 3 metres long
- 40 mm in diameter

GI pipes are used as earthing electrodes.

Natural Earthing: Bore should be so deep that it reaches the water level.

Artificial Earthing: Bore should be deep enough to reach the moisture level.

Placing Electrode Inside the Bore



The electrode is inserted inside the bore and is then removed to see the depth.

Placing Electrode Inside the Bore



After checking the depth of the water or moisture level, the lineman again places the electrode inside the bore.

Earth Resistance Testing Tools

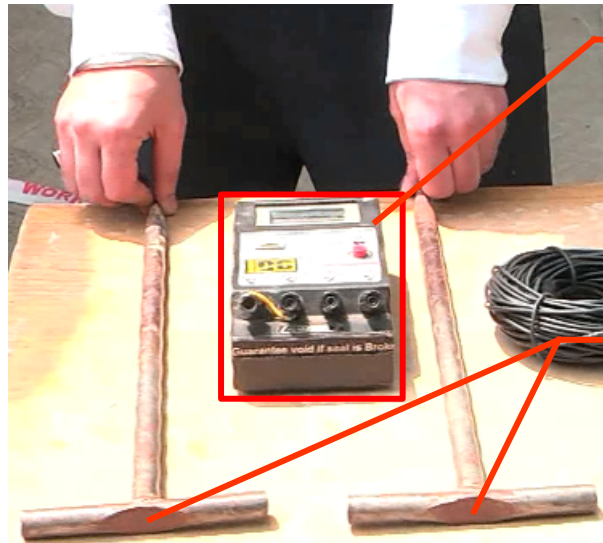

Digital Earth Resistance Tester

Spikes

Parts of Digital Earth Resistance Tester



At the backside of connections diagrams are s

Terminals

Connection diagrams for the wires to be connected to the spikes

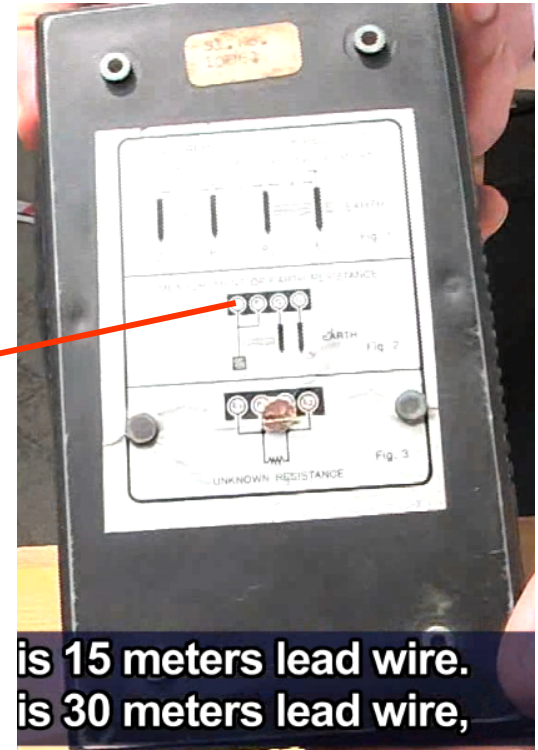

is 15 meters lead wire.
is 30 meters lead wire,

This is used for earthing terminal.

Lead Wires



30-metre lead wire

15-metre lead wire

Used for earthing terminal

Fixing Spikes and Wires to Tester



● The first spike is kept 30 meters away

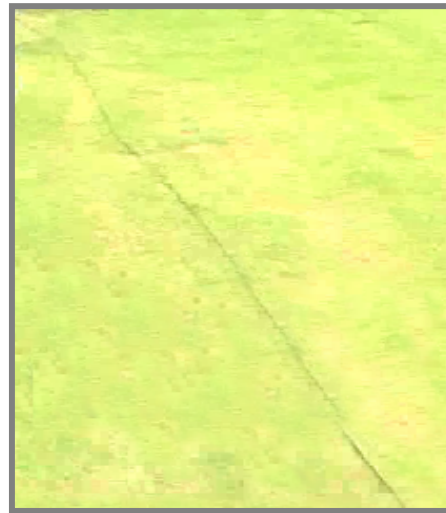

● 30 metre lead wire



● 30 metre lead wire

Fixing Spikes and Wires to Tester

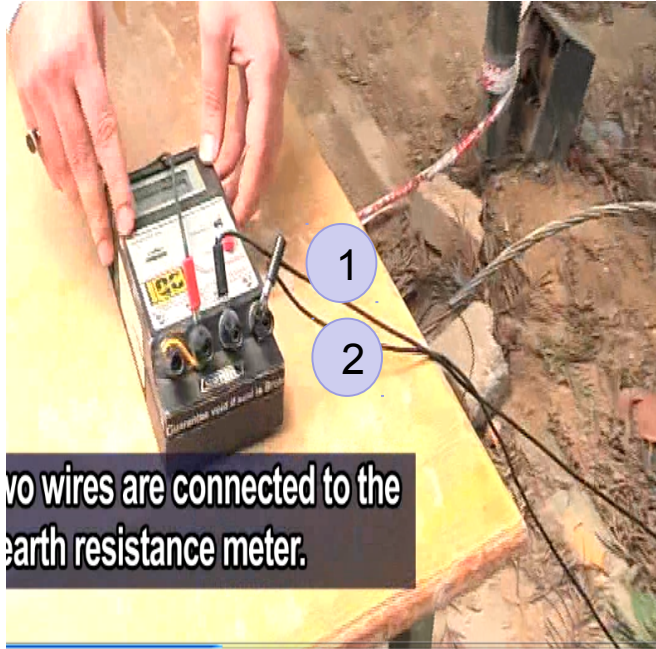

Two wires are connected to the earth resistance meter.

Lead wires are connected to the earth tester



Wires are connected to the earth resistance meter.

The third wire is connected to the earthing electrode

Measuring Earth Resistance

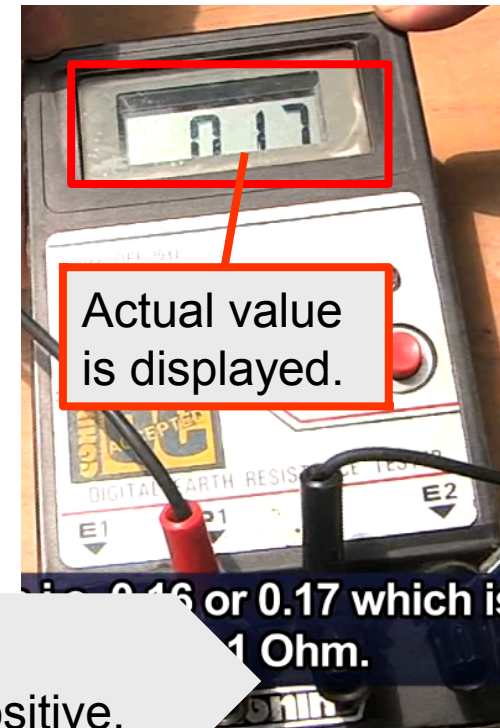

The value is between **0.16** and **0.17**.
Since this value is LT 1 Ohm, this test is considered positive.

Tips to Maintain Earth Resistance

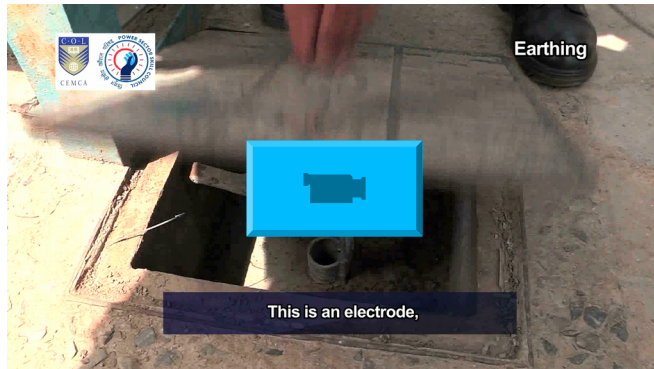

- Electrode has a layer of salt and coal to maintain the moisture
- During summer season, level of water decreases
- To maintain the moisture, pour some water regularly, once a month

Other Tips:

- Increase the depth of electrode
- Increase the size of electrode
- Increase the number of electrodes

If earth resistance is too high, dig 1-metre deep pit near the electrode. Fill the pit with saline water so that the electrode remains in contact with the saline water.

Use of Lightning Arrestors (LAs)



There are 3 LAs on the line



These are connected to the main line and the earthing terminal

LAs transfer extra charge into the earth in case of overvoltage or lightning. Thus, the equipment is protected

Earthing Connections of Transformer

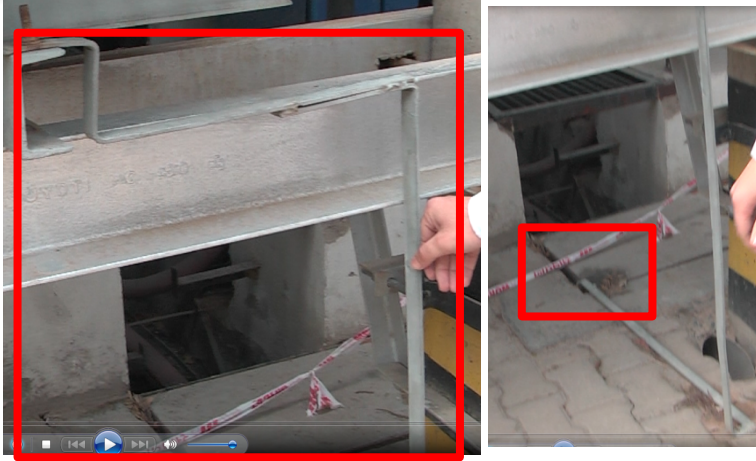

First earthing:

- Connected to the body of the DP
- Goes into 1st earthing pit

Second earthing:

- Connected to the body of transformer
- Goes into 1st earthing pit



Third earthing:

- Connected to the neutral
- Goes into 2nd earthing pit

The earthing connected to the LAs goes into the 3rd earthing pit.

Maintenance and Improvement of Earth Resistance

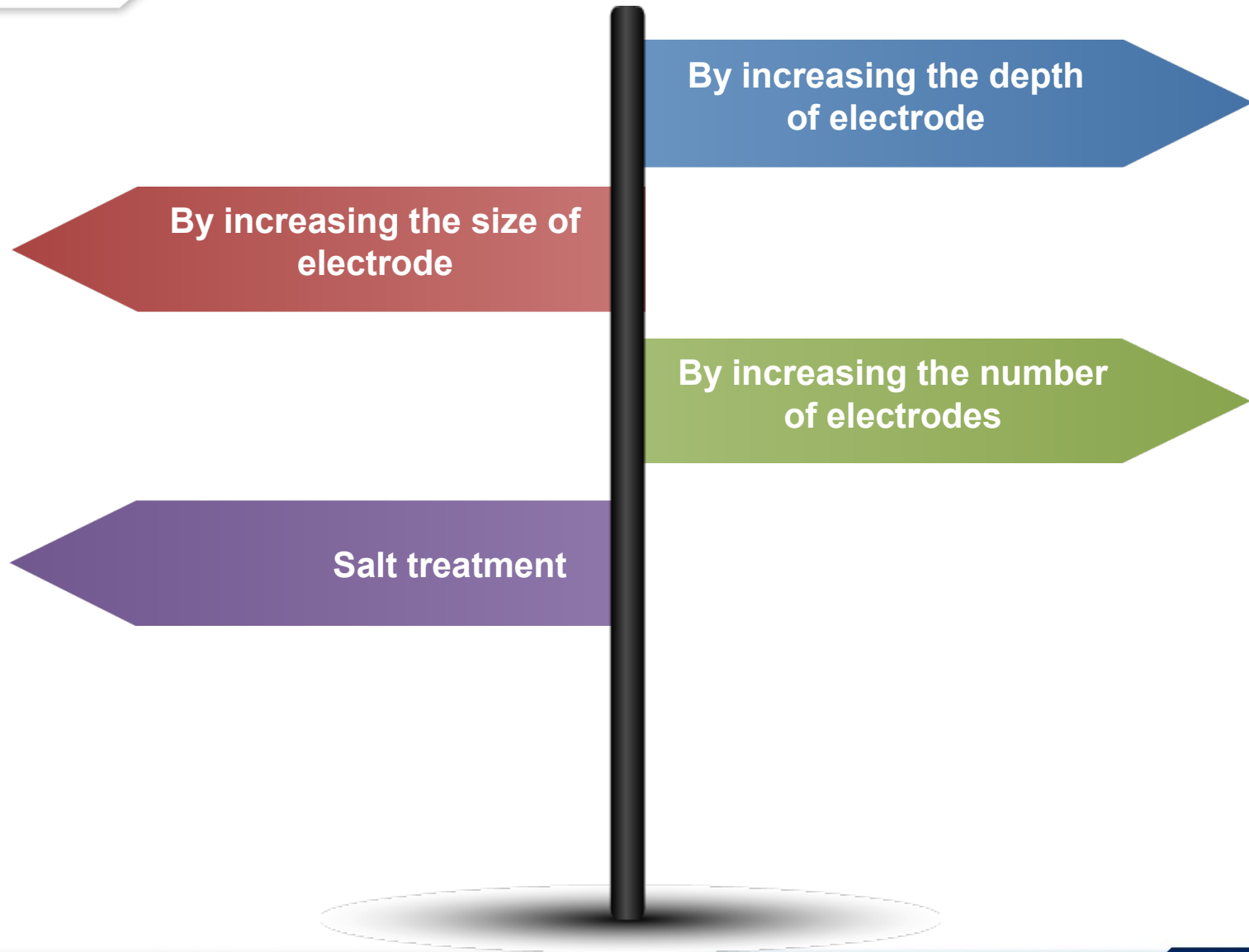

Key Learning Outcomes

- How earthing is done and how to use digital earth resistance tester to measure earth resistance
- Double earth is used for every equipment and there is a separate earth for LA and transformer neutral
- While designing an earthing, we should also know how fault current passes through the earth connection
- The cross-sectional size of earth wire is always kept on the higher side for easy flow of fault current to the earth
- The four ways of maintaining and improving earth resistance are:
 - Increase the depth of electrode
 - Increase the size of electrode
 - Increase the number of electrodes
 - Observe salt treatment

