

Hardware and Software for Multimedia Development

3

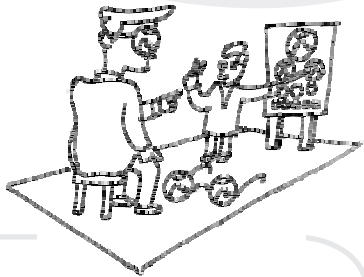

Objectives

At the end of the section, you will be able to

- Outline the hardware requirements for multimedia development;
- List various software for developing multimedia; and
- Choose suitable software for developing multimedia.

Computers are now making it possible to combine sound, images and motion together. In earlier sections, you have read about definitions of multimedia as propounded by experts. You can now describe the use of multimedia in educational settings. In this section, we introduce you to the inside story of multimedia i.e. about the hardware and the software which enable you to get the end product called 'multimedia'. Understanding these concepts is very important as it is only the hardware (the computer), the software (tools for designing multimedia) and yourself (your conceptual understanding and skills) which will be crucial for multimedia development. In this section, we will confine ourselves to the Microsoft Windows platform only. There are other platforms also like Apple Macintosh, Silicon Graphics, Sun Microsystems and even mainframes. Since Windows-based systems (or Windows operating systems) have a worldwide presence, availability and affordability, it becomes an automatic choice for our purpose. In this section you will learn about the hardware and the software. In fact the software tells the hardware as to what to do. This section also highlights the software that enables development of multimedia. You will also learn about some of the ways to choose the best combination of hardware and software to suit your requirements.

The developments in the field of hardware and software for multimedia are such that it is practically impossible to be current in print. The description in this section is only informative (and does not necessarily claim to be exhaustive) for enabling you to familiarize with the concepts and capabilities of some of the software used in developing multimedia.

An *operating system* is the program that is responsible to manage all the other programs in a computer, once it is loaded into the computer. The other programs are called *applications* programs. The operating system determines the distribution of time and order for multiple application programs running simultaneously. It also manages the sharing of memory among multiple applications. It communicates with the attached hardware devices about the condition of operations and any errors that may have occurred. Linux and Windows 2000 are examples of operating systems while MS-Word is an example of an application program.

In this section we discuss various terminologies used in computer operations and usage to emphasize their importance in multimedia development.

Hardware required for Multimedia

To begin your quest with a multimedia project you must have a decent computer. A decent computer means you should have adequate hardware. Hardware interprets your commands into computer activity. As of now, if you are asked to develop a multimedia project, you would ask for a fast computer with lot of speed and storage. There are many more things that you need to know like which component makes a computer fast, what is the device for storage, etc. The components are thus divided into five categories viz. *System devices, Memory and storage devices, Input devices, Output devices, and Communication devices.*

System devices

These are the devices that are the essential components for a computer. These include microprocessor, motherboard and memory. Microprocessor is basically the heart of the computer. A *microprocessor* is a computer processor on a small microchip. When you turn your computer on, it is the microprocessor, which performs some operations. The microprocessor gets the first instruction from the *Basic Input/Output System* (BIOS), which is a part of its memory. BIOS actually loads the operating system into random access memory (RAM). A *motherboard* is a device in the computer that contains the computer's basic circuitry and other components. Motherboard contains computer components like microprocessor, memory, basic input/output system (BIOS), expansion slots and interconnecting circuitry. You can add additional components to a motherboard through its expansion slot.

Memory and Storage devices

RAM (random access memory), also called primary memory, locates the operating system, application programs, and data in current use so that the computer's processor reaches them quickly. RAM is called "random access" because any storage location can be accessed randomly or directly. RAM is much faster than the hard disk; the floppy disk and the CD-ROM. RAM can be taken as short-term memory and the hard disk as the long-term memory of a computer. However, RAM might get slow when used to its limit. That is why, you need more memory to work on multimedia. Today's personal computers come with 128 or more *megabytes* of RAM.

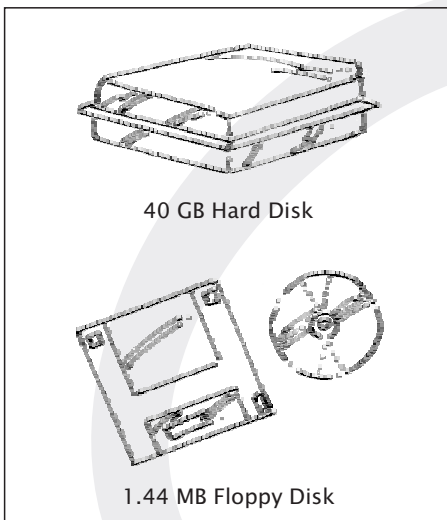
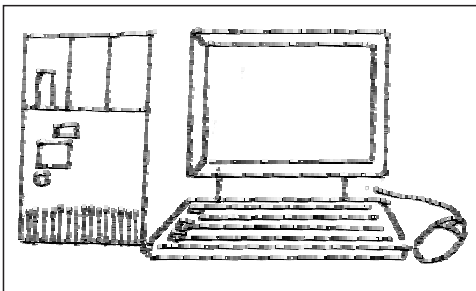

Users of graphic applications usually need 128 plus megabytes of memory.

A *hard disk* stores and provides access to large amounts of data on an electro magnetically charged surface. Today's computers typically come with a hard disk that contains several billion bytes (gigabytes) of storage. The popular ones currently are 40 GB and above. Hard disk contains a part called *disk cache* which is responsible for improving the time it takes to read from or write to a hard disk. The disk cache holds data that has recently been read. The other type of hardware cache inside your computer is cache memory. Cache stores something temporarily e.g. Temporary Internet files are saved in Cache.

A *compact disc* (CD) is a small medium that can store data pertaining to audio, video, text, and other information in digital form. Initially, CDs were read-only, but newer technology allows users to record as well. *CD-ROM* (Compact Disc, read-only-memory) can store computer data in the form of text, graphics and sound. To record data into a CD, you need a *CD recorder*. Normally this type of CD is either *CD-Recordable* (CD-R) or *CD-Rewritable* (CD-RW). For the latter you can use the CD as a floppy disk write, erase and again write data into the same disk. In the CD-R, once the data recording is completed, it becomes a CD-ROM and nothing can be deleted.

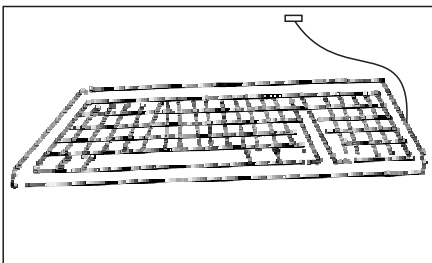

Input devices

A *keyboard* is the primary text input device for your computer. It was very popular when DOS was the popular operating system. After the emergence of Windows, its role became limited to dealing with text and for some commands only. The keyboard contains certain standard function keys, such as the *escape key*, *tab*, *cursor movement keys*, and *shift* and *control keys*. A mouse is also a primary input device but it is not suitable for dealing with text.

A *mouse* is a small device that you move across a pad in order to point to a place on a display screen and thus execute a command by clicking it. The mouse is an integral part of any personal computer. A cable connects the mouse to the computer.

Microphone is another input device that can interpret dictation and also enable us to input sound like the keyboard is used for text.

A *digital camera* records and stores photographic images in digital form that can be fed to a computer as the impressions are recorded or stored in the camera for later

loading into a computer. The digital cameras are available for still as well as motion pictures.

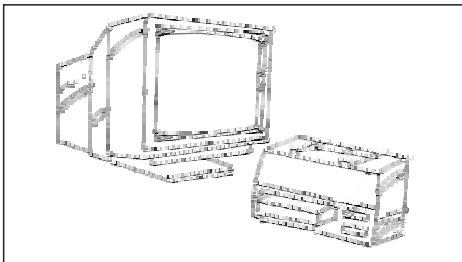

Output devices

A *printer* is a device, which on receiving the signal from computer transfers the information to paper. Earlier the *dot-matrix* printer was a popular low-cost personal computer printer; now *inkjet* printers have taken its place. Dot-matrix printer strikes the paper a line at a time while inkjet sprays ink and laser printer uses a laser beam to attract ink (also called *toner*). A *monitor* is a device for display. It is just like a television set and is measured diagonally from two opposing corners of the picture tube. The standard monitor size is 14 inches. Very large monitors can measure 21 inches diagonal or greater.

An *amplifier* is an electronic device that increases the power of a signal. Amplifiers are used in audio equipments. They are also called *power amplifiers*. Speakers with built-in amplifiers have become an integral part of the computers today and are important for any multimedia project.

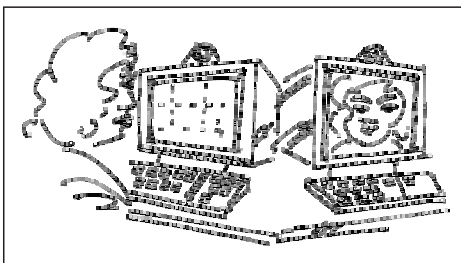

Communication devices

A *modem* modulates *digital signals* going out from a computer or other digital device to *analog signals* for a telephone line and demodulates the analog signal to convert it to a digital signal to be inputted in a computer. Most new personal computers come with 56 Kbps modems. Modems help your computer to connect to a network.

Additional Hardware

You are now aware of the basic devices on your computer. However, there are a few more devices that you should know. Video capture is one of the most important hardwares to be used for multimedia work on a personal computer. Video-capture results will depend on the performance and capacity of all of the components of your system working together. *Video capture* from analog devices like video camera requires a special *video capture card* that converts the analog signals into digital form and compresses the data. Video-capture card use various components of the computer to pass frames to the processor and hard disk. For good quality video, a

video-capture card must be able to capture full-screen video at a good rate. For example for a full-motion video, the card must be capable of capturing about 35 frames per second at 720 by 480 pixels for digital video and 640 by 480 for analog video. To determine what settings will produce the best results for your projects, you must be careful in defining these parameters.

A *sound card* is a device that attaches to the motherboard to enable the computer to input, process, and deliver sound. The sound card generates sounds; records sound from analog devices by converting them to digital mode and reproduce sound for a speaker by reconvertng them to analog mode. *Creative Lab's Sound Blaster* is a standard sound card, to the extent that some people use the name as a generic term.

A *video adapter* provides extended capability to a computer in terms of video. The better the video adapter, the better is the quality of the picture you see. A high quality video adapter is a must for you while designing your multimedia project.

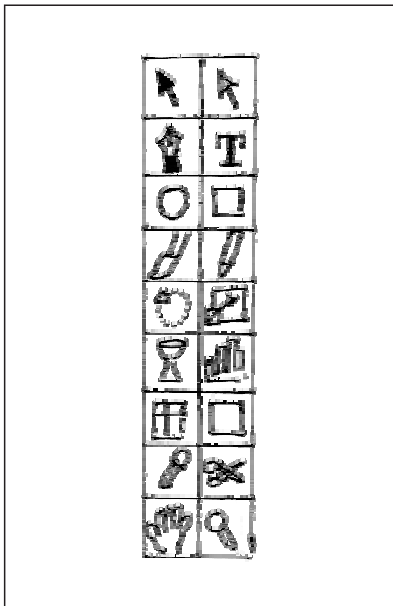

Configuration of a Multimedia Computer

A good multimedia system should have a Pentium 1.6 Ghz (or the one with similar capabilities) onwards processor, at least 256 MB of RAM, 40 GB onwards hard disk drive, 1.44 MB Floppy drive, 17 inch onwards SVGA monitor, 32MB AGP card, 52 X CD-ROM drive, a 32 bit sound card, high wattage sub-woofer speakers, 104 PS/2 keyboard, PS/2 mouse and 56K fax data voice modem. If you wish you can add a CD-recorder, scanner, printer, digital camcorder and a video-capture card. Remember, there is no set rule to define the exact hardware combination of a good multimedia computer. The combination is dependent on the nature and contents of the multimedia project you are dealing with. Fortunately, there exist hardware tools for performing almost any action; the need is to use only that hardware, which suits your purpose. For a ready reference, see table-1:

Multimedia design software

The basic tool set for building a multimedia project can be divided into five categories: *Painting and drawing tools*, *3-D Modeling and animation tools*, *Image editing tools*, *Sound editing tools*, *Animation Video* and *Digital Movie tools*. The software in your multimedia toolkit and your ability to use it will determine the quality of your multimedia work.

Table-1 : Components of a Multimedia PC

Component	Description	Standard
The Power Supply	It converts AC current into DC current as all computer components operate on DC current.	Any standard ATX Cabinet.
The System Board	All of the parts inside the computer are assembled on the system board.	Prefer to buy genuine board for the processor. Intel web-site has a motherboard selection feature.
Central Processing Unit (CPU)	The CPU is the brain of the computer. Pentium is a popular chip presently.	Pentium 4 processors, AMD etc, with 1.5 GHz speed onwards.
RAM (The Memory)	Random Access Memory (RAM) is critical for multimedia. The more memory the better off the computer is.	Minimum 256 MB
The Floppy Drive	A floppy drive is a storage device for smaller files (1.44 MB)	Buy any 1.44 MB
Hard Drives	Hard disk drive stores software and data. More storage is better for large projects.	40 GB onwards
CD Drive (read/write)	CD drives can store what hundreds of floppy disks together can. Maximum capacity of CD is about 800 MB presently.	ROM - 52 X RW 48X x 16X
Modem	Modem enables communications between your computer with other computers, the Internet and the World Wide Web.	56 kbps onwards
Sound Card	Sound Cards allow conversion of digital sound to analog sound and vice-versa.	Sound Blaster e.g. Creative Live Value Card
Keyboard	The keyboard sends typed information to the system board.	Multimedia Key Board
Monitor	Monitor is a display device. Choose how many colors they can display and about their resolution.	17"
Mouse	Mice are used as a pointing device.	Scroll Mouse
Printer	Inkjet printers have the ability to turn out good-looking output, including graphics at a lower cost than laser printers. Laser printers produce the best quality, but their cost is high	Choose as per your requirements.
Scanner	Scanners are used to digitize photographs, artwork and documents.	Choose as per your requirements.
Digital Camera (Still/ movie)	To capture pictures and prepare movie.	Choose as per your requirements.
Video Capture Card	To capture analog video and convert into digital format	Choose as per your requirements.
Graphics Card	To view graphics on the screen clearly.	32 MB Minimum

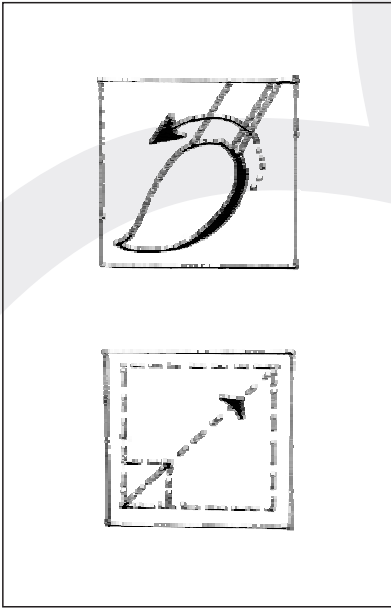

Painting and drawing tools

Graphic impact of your multimedia presentation is very important in influencing the students. It is the graphics that would create the first impression of your multimedia project. These tools are, therefore, very useful in giving you the desired capability in terms of drawing and painting. Painting and drawing tools generally come with a graphical user interface with pull down menus for quick selection. You can create almost all kinds of possible shapes and resize them. These tools have the capability to color with paint and clip arts. One can use brushes of different sizes and shapes according to the need. One can use layers to give different treatment to each element. Most of these tools come with built-in plug-ins for performing different tasks. Once you are done with the drawing it can be imported or exported in many image formats like .gif, .tif, .jpg, .bmp, etc. We will give a brief description of a good drawing software known as *Corel Draw*.

With *Corel Draw*, you can create illustrations from scratch. It has wide-ranging features to handle text and to create drawing with precision. It can be used to improve clip art, pictures and photos. It is an ideal tool for any design project like technical drawings, advertisements, logos, etc. It can be used in creating full-color illustrations for multifarious drawings and graphics for any designing project. It has lot of clip arts and high-quality drawings, which can be inserted into your multimedia project. One can also generate drawing for an animation sequence by using *Corel Draw*.

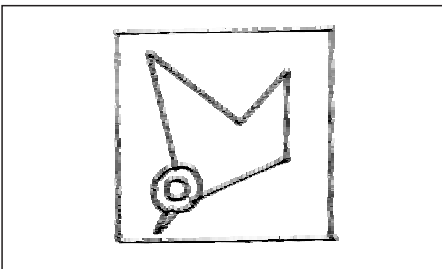

3-D Modeling tools

Realism means that you depict things in the way they actually are. With the help of 3-D modeling and animation tools the objects that appear in perception in your project can look realistic. It has become conventional to use 3-D modeling in multimedia design. These tools offer features like multiple windows to view your design in each dimension. They have *drag* and *drop* menus from where you can drop shapes into your design and combine them to create complex designs. A good 3-D modeling tool is 3D Studio Max.

3D Studio Max is a tool for making 3D models and designs that can be converted into 3-dimensional animations. You must have seen many websites with animated symbols. In fact many of such symbols are made by using this tool. You can virtually lead your imagination to go wild and visualize any symbol easily with the help of this

tool. It has applications in creating web pages; designing advertisements; making cartoon films and in creating multimedia based training programmes. One can give special effects to the design especially in terms of sound and animation.

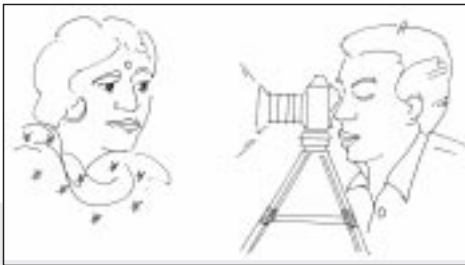
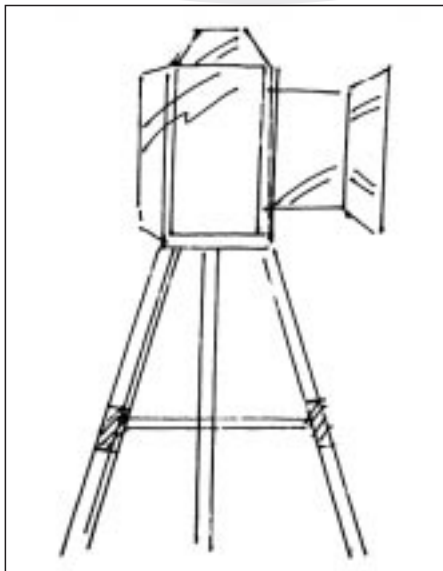

Image editing tools

While Painting and Drawing tools let you create a drawing from scratch, Image editing tools are used to edit existing bitmap images and pictures. However, these tools are similar to painting and drawing tools as they can also create images from scratch. They are capable of converting any image data type file format. Image editing tools are primarily used for reinventing and recreating the image, which make them an important tool for designing a multimedia project. We will introduce two good image processing software here: *Adobe Photoshop & Paint Shop pro*.



Adobe Photoshop is a cutting-edge image processing software package that enables you to create and edit images on computers. *Paint Shop pro* is also an exceptional drawing and painting utility that yields professional-quality effects. With both these tools you can edit an image in almost any desirable way. One can add elements in layers; edit text and use effects filter to make the existing image look even inferior to the edited one. It can mix and manipulate colors at a click of a button. You can manipulate your images with special effects and techniques. Images can be imported and exported across programs in any format. These tools have been used to edit and create images for motion pictures, animations and for artwork. With the help of these tools, you can master the special effects you've always wanted.

Sound editing tools

Sound editing tools let you hear sound as well as visualize it. You can cut/copy and paste sound and edit it with great accuracy. You can integrate sound into your multimedia project very easily by using sound editing tools. One such software is *Cool Edit*.

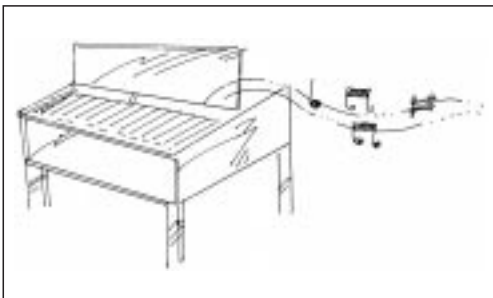

Cool Edit can be used to record your own music, voice, or any other audio. It makes you a professional as far as handling of sound is concerned. You can edit, mix the sound with any other audio and add effects to it. *Cool Edit* can record from a CD, keyboard, or any other sound played through your sound card. One good feature of this software is that it can read and write MP3, which is the hot sound format in the

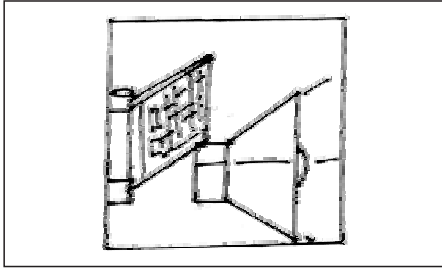

present times. Once you are done with your sound file, it can help you in converting the file to any desired format. In other words, there is a similarity in these editing tools--what Photoshop can do to images; *Cool Edit* can do for sound.

Sound Forge is another professional quality sound editing tool that is used in multimedia work.

Animation, video and digital movies editing tools

Animations are graphic scenes played back sequentially and rapidly. These tools adopt an object-oriented approach to animation. These tools enable you to edit and assemble video clips captured from camera, animations and other sources. The completed clip with added transition and visual effects could be played back. Adobe Premiere and Media Shop Pro are two good examples of these tools.

Adobe Premiere is a powerful tool for professional digital video editing. It is primarily used to produce broadcast quality movies. It has excellent editing tools that enable you to work with complete flexibility. This software first digitizes the sound and video and then allows you to edit them to preserve picture quality. It can edit video and multimedia movies in AVI as well as MPEG format. It can create titles and graphics and then add them to your multimedia project. It uses digital filtering for incorporating special effects. This software has applications in film editing and movie making.

Media Studio Pro also gives you the most complete set of advanced video editing tools. It can capture the video from VCR, TV or camcorders. It is capable of capturing a batch of scenes. It brings all the components of a multimedia project like video, sound, animation and titles together. One can add effects and transitions and finally save the video in the desired format. It can retouch videos by painting directly over any frame in a video sequence. It has an audio editor, which can remove background noise and add another sound to your video.

For creating animations *Macromedia Flash* is the industry standard. A file created in Flash is called a movie. A movie in Flash occupies very less file size, and hence is more popular for the Web. You can also create presentations and 2D Animations using Flash.

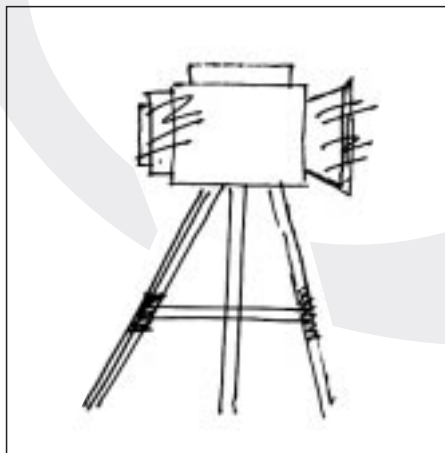

Integrated Design Software

Multimedia authoring tools are tools which organize and edit your multimedia project. These tools are required to design the user interface for presenting the project to the learner. In other words, these tools are used to assemble various elements to make a single presentation. You can compose comprehensive videos and animations with these tools. There are four basic type of authoring tools viz. *Page based tools* (like Tool book, Visual Basic), *Icon based authoring tools* (like Authorware), *Time based authoring tools* (like Macromedia Director) and *Object Oriented tools* (like Media Forge).

Page-based tools organize elements as pages of a book. These tools are used when the content of the project consists of elements that can be viewed individually. These tools organize them in a user-defined sequential form. *Icon based tools* organize elements as objects. These tools display the flow diagrams of activities along with branching paths. *Time based tools* organize the elements along a time-line. These tools play back the sequentially organized graphic frames at user-set speed and time. *Object Oriented tools* organize the elements in a hierarchical order as related “objects”. These tools make these objects perform according to properties assigned to them.

We will give here a brief description of two such tools Authorware (Icon based) and Macromedia Director (Time based).

Macromedia Authorware has a visual interface, which one has to simply drag and drop icons to create an application. You do not need to be a programmer to use this software as it has an interactive design. Authorware provides direct support for graphics and animations made in Flash. Authorware can capture and integrate animations and video made in different programmes like Flash and QuickTime. It can integrate sound into your project in order to enhance the effect. It has an anti-aliasing feature which smoothes out the edges of text and graphics. Authorware has built-in templates which give you flexibility and convenience while developing your project. You can learn about basic authoring, editing and publishing ways with the help of a multimedia tutorial which is built-in with this software.

Macromedia Director is a multimedia authoring application capable of producing animations, presentations and movies. It provides a wide range of possibilities for integrating different multimedia elements. It supports inputs from programs like *Shockwave*, *Photoshop* and *Premiere*. It has applications in building professional

Table-2 : Choosing software

Features	Description
Usability	Should have a capability to deal with a variety of text, images video and sound formats with precision and ease.
Animations	Should have wide ranging capabilities in terms of interactive simulations, media support, animated buttons, illustrations,maps,etc.
Smoothness	Should have anti-aliasing feature, meaning that all letter and image edges are smooth.
Integration	Should have integration capabilities with a wide range of software used for different jobs like Real, ActiveX, Shockwave, Flash, QuickTime, Photoshop and other applications .
Delivery	Should be able to develop one piece of content for delivery on different media types.
User freindliness	Should be the easiest, most versatile, and have the most pre-built models .
Clientele	Should have applications for instructional designers, subject matter experts, training developers and others.

multimedia presentations. You can also integrate Real Audio and Real Video in Director projects. Compatibility of Director with other packages means that you can use your favorite tools and software to create content for your project and then bring that content into Director for authoring.

Choosing Multimedia Software

Multimedia is making a difference by providing ways of delivering learning materials that are less expensive and more convenient. The key to any learning process is that it must be relevant and it must keep the learner engaged. Educational multimedia is no exception. This can be proved after seeing the growing use of graphics, illustrations, animations and sound in educational multimedia. It is therefore essential to choose that software which enables you to execute your project with the minimum possible effort and maximum possible productivity. Multimedia software have unlimited features. You can choose among several hundred colors, dozens of fonts, a wide variety of color-coordinated templates and many other incredible options. Before starting to select software, one should start with an outline of the project and decide what is expected from the project. Table-2 gives a ready reckoner for selecting software.

Hardware is the first thing that you should have to begin your quest with a multimedia project. Hardware is necessary to interpret your commands, queries and responses into computer activity. You have read about hardware components viz. system devices, memory and storage devices, input devices, output devices and communication devices. Fortunately there is an abundance of good hardware answers to almost every problem. These areas are fast getting converged. May be tomorrow you would be able to see some more innovative steps in this direction which offers you even better capabilities.

Similarly in software too, entire suites of integrated production tools are now available. The need is to use them judiciously to create good projects. Powerful features are continuously being added to the software that allows developers to work more smoothly and conveniently between applications. Emergence of these integration features has resulted in collaboration and unison of multiple tools. The integration has enabled us to use your graphics from a previous work and save time on rebuilding it.

In short, the options available are enormous. All that you have to do is to choose the right hardware and software to complete your multimedia projects.

In the next section we will discuss about learner characteristics in order to develop good programme for them.